

DREAM XXI G

LPG REDUCER
/ REGULATOR



FEATURES

- » Two stages, vacuum compensated
- » Integrated shut-off valve
- » Integrated gas liquid-phase filter
- » Integrated water temperature sensor (optional)

TECHNICAL SPECIFICATIONS

Max. working pressure	30 bar
Weight	1580 g
Overall dimension	199 x 150 x 123
Max. gas flow rate	46 Kg/h
Output setting pressure	1.7 bar
Operating temperature	-20 °C » 120°C

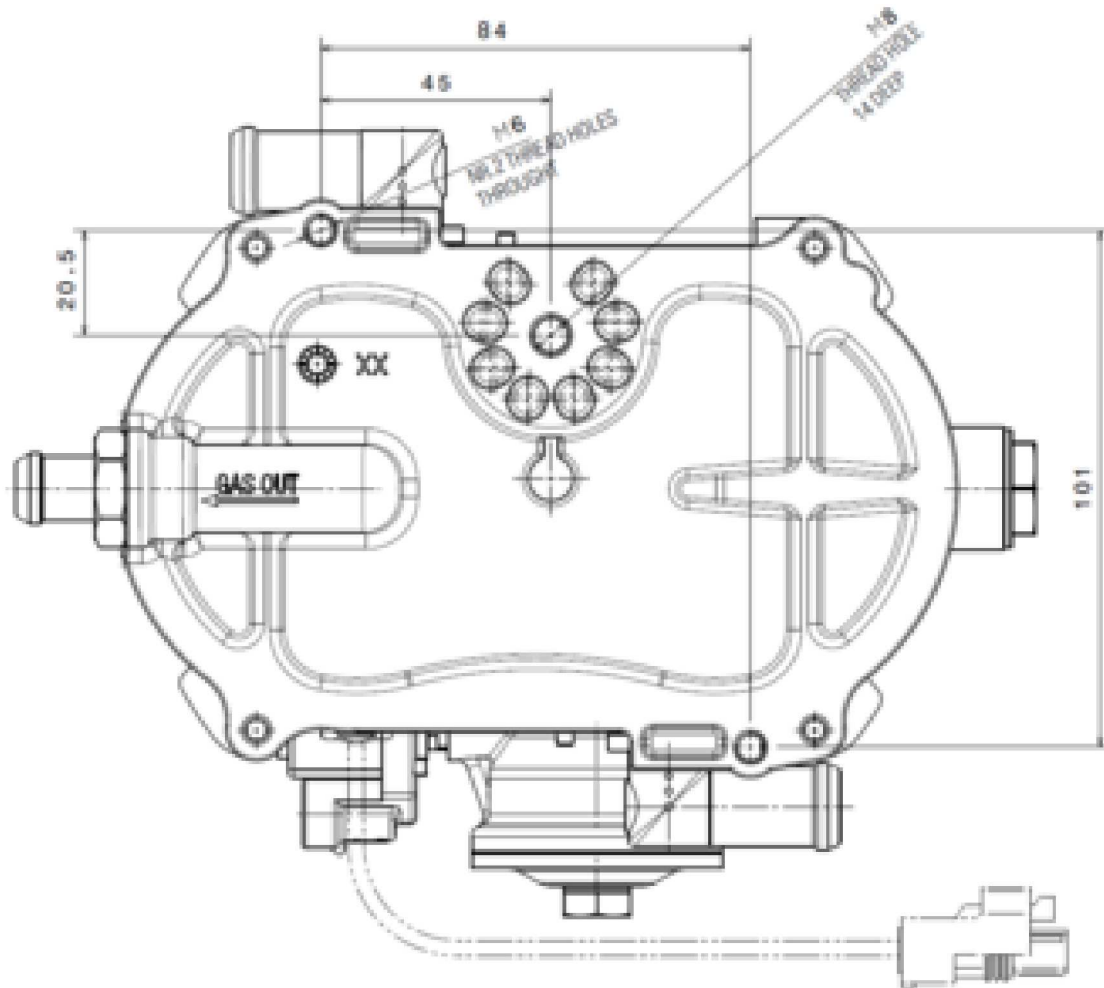

DREAM XXI G back view

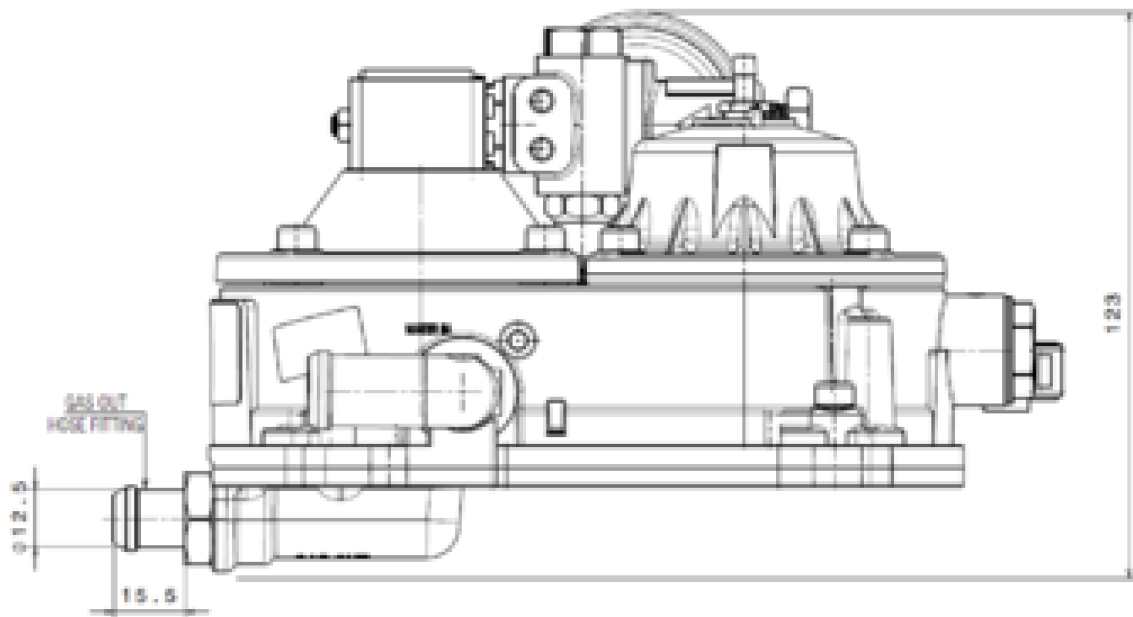

DREAM XXI G top view